



VERTA™ SERIES



Verta [värd]

1. From Swedish (“worth, worthy”)
2. (archaic) match (equal or superior in comparison)

A NEW LEVEL OF DESIGN

Design elevates the functional to the sublime. Clever design is unobtrusive, yet distinct. Beautiful design delights the senses, challenges us and inspires joy every day.

Inspiration is a source of innovation. Stemming from modern trends, Verta showcases the synchronicity between inspiration, innovation, design and style.

Architectural lines create surfaces that reflect light in every direction; tactile surfaces surprise and delight; lineal planes soften to curved edges – Verta’s design features set a new standard for innovative style.



**“Design is a tool we
use to touch people,
engage their senses and
enhance their lives.”**

Michael Graves, Architect

DESIGNED RIGHT HERE

Our design story starts with a vision of a designer range of door and window furniture with a modern twist.

A locally based team of design specialists developed that vision further, influenced by classic designs, modern trends and architectural spaces.

Starting with a classic square shape, the designers added in subtle design features to define, elevate and modernise.

From the bevelled edges to soften hard lines, architectural lines to reflect light and gently curved handles for tactility, Verta is a modern reinvention of a classic; precisely engineered functionality with design at its core.

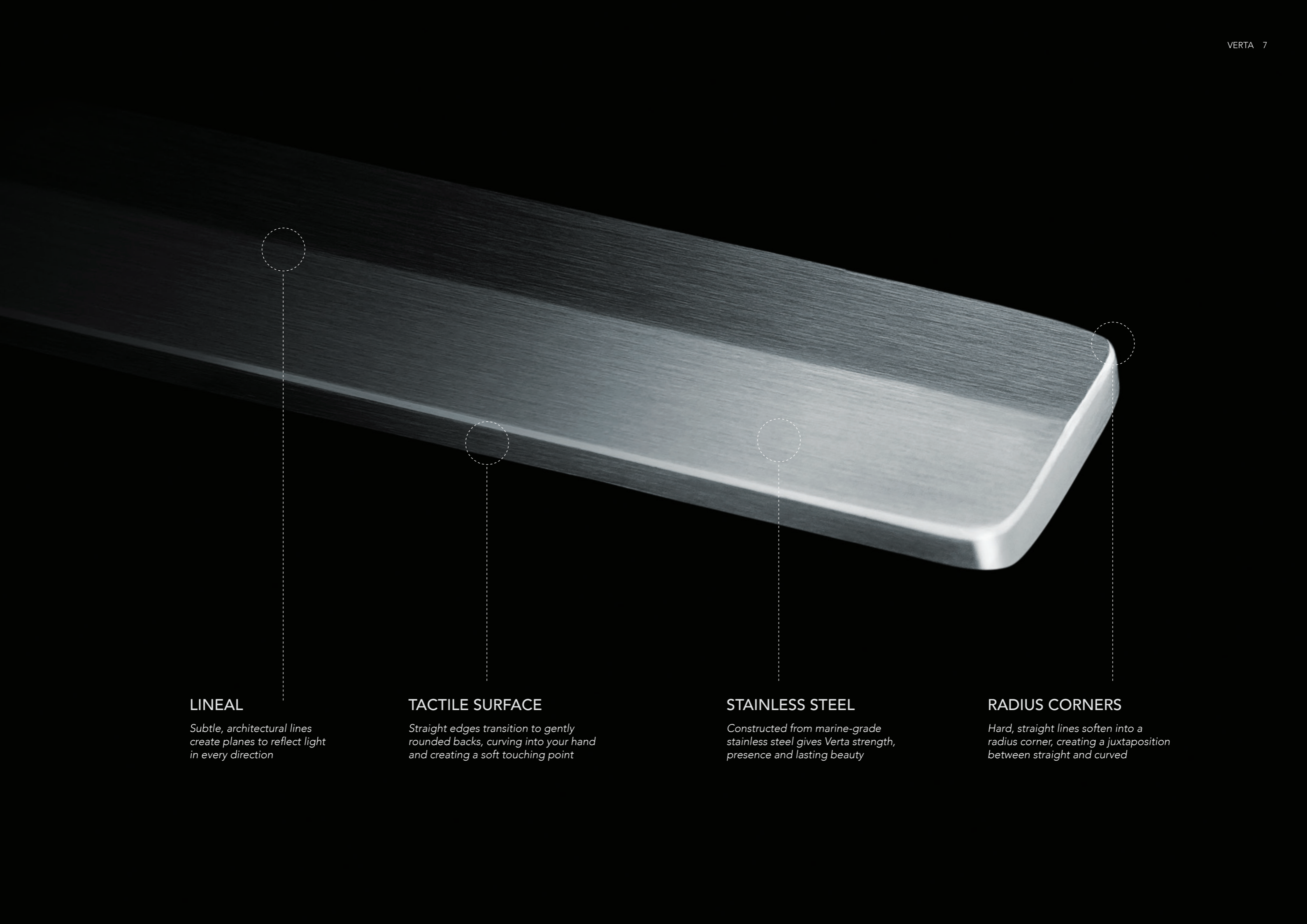

LINEAL

Subtle, architectural lines create planes to reflect light in every direction

TACTILE SURFACE

Straight edges transition to gently rounded backs, curving into your hand and creating a soft touching point

STAINLESS STEEL

Constructed from marine-grade stainless steel gives Verta strength, presence and lasting beauty

RADIUS CORNERS

Hard, straight lines soften into a radius corner, creating a juxtaposition between straight and curved



ALL THE ELEMENTS

Beautifully designed products need attention to detail from creation to completion. Every element of Verta has been sourced, crafted and finished by experts.

Each piece of Verta is constructed from stainless steel. We start with one of the highest grades of stainless steel available - 316 marine-grade - sourced from an expert in the material.

No compromise is made during construction. Solid stainless steel is used throughout, moulded nylon tips are seamlessly melded to vents, radius corners are micro-millimetre perfect and curved edges are polished with watch-maker precision.

After construction, Verta is tested. And tested. And tested again. To endurance standards of 200,000 cycles.

Verta's precision engineering, uncompromised design and superior construction is the perfect balance between functionality and beautiful design.



Entrance Pull Handle

GRAND ENTRANCES

Create a grand entrance to your home with Verta's Entrance Pull Handle. Make a bold statement with your front door and showcase stylish accents throughout your home.

Enchant your visitors with classic lines and modern design; delight senses with tactile surfaces, hard steel and soft edges. Enjoy a grand entrance each time you enter your home.

Constructed from solid, 316 marine-grade stainless steel.
Suitable for internal and external use.



**“Fashion is architecture:
It is a matter of proportions.”**

Coco Chanel

OPEN UP

Close one door, open another. Hide away or reveal a room. Match the back door to the front, use the same lever on a cupboard as on the bedroom door. Inside or out, Verta's designer accents reflect and enhance your individual style.

Constructed from solid, 316 marine-grade stainless steel.

Windows



Low Profile

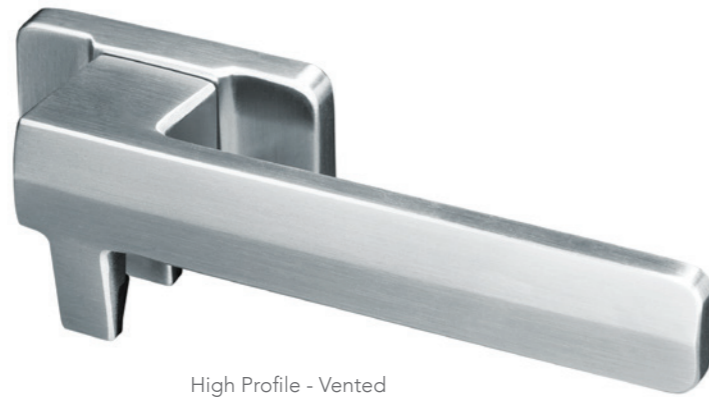

High Profile - Vented

BREATHE

Let fresh air in. Circulate, cleanse and breathe. Create fresh, invigorating spaces throughout your home with vented window fasteners. Cleverly designed, Verta's window fasteners open up unobstructed views and blend seamlessly into any interior.

Constructed from solid, 316 marine-grade stainless steel.
Available in high profile (vented) or low profile options.
Non-marking load pads.



Non-marking load pads

**“Love of
beauty is taste.
The creation of
beauty is art.”**

Ralph Waldo Emerson

**“Beauty awakens
the soul to act.”**

Dante Alighieri



Bi-fold Lever



Escutcheon



Flush Pull



Pull Handle

VISTAS

Bring the outside in. Create open spaces or snug hideaways. Transform a room, change spaces and enhance beautiful vistas. Verta's range of sliding and bi-fold door furniture gives you the freedom to create spaces you love.

Constructed from solid, 316 marine-grade stainless steel.
 Bifold operator designed for interior applications
 Sliding door pull handle suitable for internal and external use.



Entrance Pull Handle
800mm length



THE VERTA SERIES

A classic shape reinvented with modern design and precision engineering, Verta will enhance your home inside and out. From the striking entrance pull handle, to the ingenious design and detailing of the vented window fasteners, Verta will add designer accents to every aspect of your home.

With a substantial 10 year mechanical warranty, Verta is an investment in quality and style for now and the future.

Sliding Door Pull Handle
300mm length



Flush Pull



Long-plate Lever



Window Fastener
Low profile
High profile

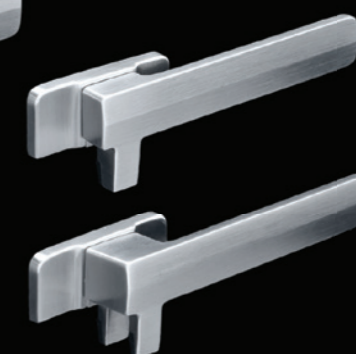

Internal Door Lever

Available in Passage,
and Dummy functions



Escutcheon



Bi-fold
Lever



Euro Cylinder
Escutcheon



Oval Cylinder
Escutcheon



Emergency
Release



Privacy Turn





For more than a century,
Schlage has helped protect
what matters most –
peace of mind.

Trusted in over 40 million homes, we strive to enhance everyday life by delivering door hardware and access control solutions focused on reliable experiences, modern simplicity, thoughtful innovation, and a dedication to craftsmanship. Where some see just a door, we see an opportunity to help turn a home into a haven.

Trust your home to Schlage.

www.schlage.co.nz

ALLEGION (NEW ZEALAND) LIMITED

Freephone 0800 477 869
Email nzinfo@allegion.com
www.allegion.co.nz

ABOUT ALLEGION™

Allegion (NYSE: ALLE) is a global pioneer in seamless access, with leading brands like CISA®, Interflex®, LCN®, Schlage®, SimonsVoss® and Von Duprin®. Focusing on security around the door and adjacent areas, Allegion secures people and assets with a range of solutions for homes, businesses, schools and institutions.

For more, visit www.allegion.co.nz



ALLEGION™